



Phone (toll-free): (888) 380-9660  
Phone (local): (973) 340-9955  
Fax: (973) 340-9933  
Web: [www.straval.com](http://www.straval.com)

20 Bushes Lane  
Elmwood Park, NJ 07407

## Model PRS11-TC

### Electropolish Tri-Clamp Sanitary Pressure Reducing Valve



- Spring diaphragm operated
- 1/2"-2" in-line Sanitary Tri-Clamp connections
- Inlet pressures to 150 PSI (~10 Bar)
- Outlet pressures 8 to 80 PSI (~5.5 Bar) (multiple spring ranges) (consult factory for higher pressures)

## Features

- **Body and flanges:** Standard material is type 316 stainless steel.
- **Trim: 316 Stainless steel** for poppet and seat is standard.
- **Internal Surface finish 20RA is standard.** Electro-polishing is optional
- **Teflon-Viton composite reinforced diaphragm** is rated pressure of 100 PSI and minimum burst pressure of 300 PSI. Teflon film on the wetted side provides good corrosion resistance to a wide range of fluids and gases including steam. Max temperature rating is 350 °F(176 °C). Viton is the elastomeric seal on the non-wetted side.
- **Sanitary Tri-Clamp type Connections** with bottom inlet, side outlet. Standard inlet flanges and outlet flanges are equal in size. Unequal flange combinations (larger outlet than inlet) are also available to compensate for expansion of gases at reduced pressures.
- **Threaded on Spring Chamber:** Produces strong clamping pressures on diaphragm. Available in 316SS (18Cr, 10-14Ni) or 300 series SS (18Cr, 8Ni)
- **Metal or Soft seat** :Several elastomer material options are available to suit various liquid or gas applications. See options in pricing section below
- **Top guided poppet** with accurately machined body bore eliminates poppet misalignment & assures proper seating under all conditions.
- **External Spring Housing:** Standard material for sanitary application is 316 series stainless steel, but 300 series stainless steel (18Cr,8Ni) can also be selected for less stringent sanitary applications, as this part is nonwetted and does not come in contact with the product flowing through the valve.

## Applications

This is a direct-acting pressure-reducing valve with an adjustable spring operating against a flexible elastomeric diaphragm subjected to the reduced outlet pressure of the valve.

This valve is used for medium flow applications. See flow Cv listed in pricing section. Unlike the PRS09-TC-V there is no piston seal with this model. Therefore, this model can operate with very low pressure differences between inlet and outlet.

This valve can be used for many fluids, clean steam, air & gases, and various products used in the food processing and pharmaceutical industry. Only clean, filtered, or strained solids free liquids and gases should be used for best operation of the valve. A strainer or filter, depending on the degree of contamination, should be installed before the inlet of the valve. **Sanitary strainers or filters** can be purchased from Straval to provide some degree of protection.

This is an unbalanced pressure-reducing valve. Therefore large variations in inlet pressure may affect the outlet pressure to some degree and should not be used for applications where holding the outlet pressure constant is important to the process. Use where inlet pressure is fairly constant.

This valve should not be used as a shutoff valve. If the valve is expected to be dead ended ( no flow passing through the valve) for prolonged periods, pressure at the inlet should be shut off, or a relief valve installed on the outlet side of the valve in case of excessive pressure buildup, reducing the life of the diaphragm or causing possible equipment damage downstream of the valve.

## Options

Select the valve size, spring range, material options in the customized pricing and ordering section indicated by the **red** arrows. You have the ability to customize your valve choices by selecting the wetted and nonwetted materials, choice of seat materials, and if you would like the valve to be electropolished. Once these selections are made a price quote can be generated and printed directly from your computer or immediately e-mailed to you.

## Principle of Operation

This valve operates on the principle of balancing the spring force that is set by the user against the outlet pressure acting under the diaphragm. There is an internal pressure balancing port that subjects the outlet pressure directly to the underside of the diaphragm. When the outlet pressure falls below the set pressure required by the system on the outlet side of the valve, the spring force overcomes the force balance under the diaphragm causing the poppet and diaphragm assembly to drop down causing the valve to open and allow higher pressure at the valve inlet to pass through the valve. When the pressure rises to a sufficient level to restore the force balance against the spring, the valve will move toward the closed position. The valve is completely self regulating and the poppet is constantly moving to respond to pressure changes on the outlet side of the valve, not the inlet. The only time the poppet closes completely is when the outlet pressure has been reached to its set point. As long as the valve is able to shut off properly without solids or other material build up in the seat or because of seat wear, the valve should be able to maintain and hold the outlet pressure and keep it from rising for brief periods of time. If the valve is set with no flow passing through the system, there will be some droop (drop in outlet pressure) caused by relaxation of the spring when the valve first has to open. This occurs with all direct spring operated valves and can be compensated by making a slight readjustment to the set pressure once the desired capacity has been achieved.

---

---

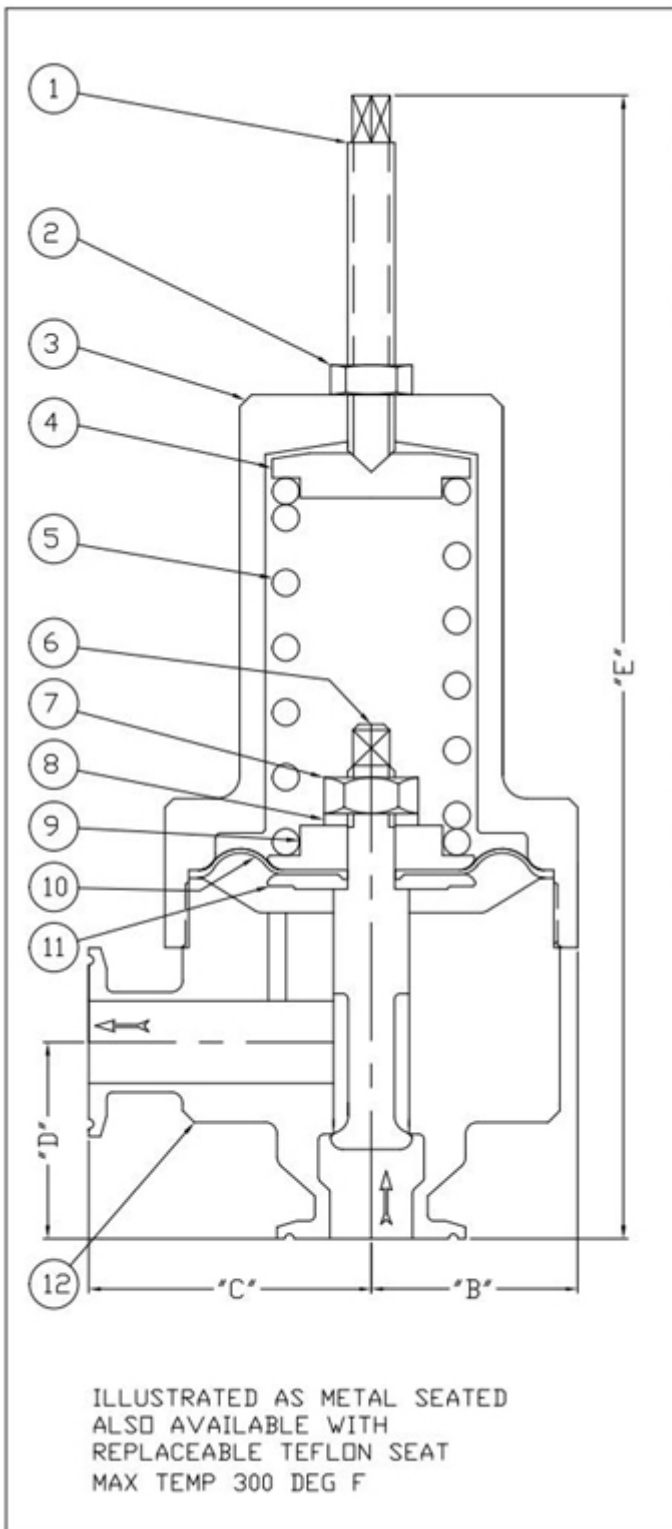

**MATERIAL LIST  
& SPECIFICATION**

1	ADJUSTING SCREW	304SS
2	LOCK NUT	304SS
3	SPRING CHAMBER	316LSS
4	SPRING PUSHER	304SS
5	SPRING	17-7PH/300SS
6	DIAPHRAGM NUT	304SS
7	MAIN VALVE	316SS
8	LOCK WASHER	304SS
9	UPPER DISC	304SS
10	DIAPHRAGM	VITON/TFE
11	LOWER DISC	316SS
12	BODY	316SS

**DIMENSIONS**

A (NPT)	B	C	D	E
1/2	1.44	2.00	2.56	8.25
3/4	1.44	2.00	2.75	11.50
1	2.25	3.00	3.00	12.38
1 1/2	2.25	3.00	3.50	13.25
2	2.25	3.00	4.31	14.38

Use this dwg for overall  
dimensional purposes

MAX INLET PRESSURE 150 PSI  
 MAX OUTLET PRESSURE 75 PSI

		PH 973-340-9955 FX 973-340-9933 23 Columbus Ave Garfield, N.J. 07006	
MATL	SS	TITLE	SS PRESSURE REGULATOR WITH TRICLOVER FLANGES
SCALE	NONE	DATE	4-3-02
DRWN	EDS	DWG NO	PRS11-Sanitary
		REV	

## 1/2" PRS11-05TC

150# Sanitary TriClamp Connections (~10 bar nominal rating)  
 Multiple Spring Ranges from:2-80 psig (0.138-5.52 barg) Select spring from pricing page

## 3/4" PRS11-07TC

150# Sanitary TriClamp Connections (~10 bar nominal rating)  
 Multiple Spring Ranges from:2-80 psig (0.138-5.52 barg) Select spring from pricing page

## 1" PRS11-10TC

**150# Sanitary TriClamp Connections (~10 bar nominal rating)**

Multiple Spring Ranges from:2-80 psig (0.138-5.52 barg) Select spring from pricing page

---

## **1 1/2" PRS11-15TC**

**150# Sanitary TriClamp Connections (~10 bar nominal rating)**

Multiple Spring Ranges from:2-80 psig (0.138-5.52 barg) Select spring from pricing page

---

## **2" PRS11-20TC**

**150# Sanitary TriClamp Connections (~10 bar nominal rating)**

Multiple Spring Ranges from:2-80 psig (0.138-5.52 barg) Select spring from pricing page

---

The spring ranges listed above are not achievable with one spring, but are compressed to show overall product capability. Select a specific spring range in the pricing pages or specify a set pressure when ordering.