



Phone (toll-free): (888) 380-9660  
Phone (local): (973) 340-9955  
Fax: (973) 340-9933  
Web: [www.straval.com](http://www.straval.com)

20 Buses Lane  
Elmwood Park, NJ 07407

## Model PRS06-EX

### Exotic Alloy Pressure Reducing Valve

PRS06 in Stainless Steel



- Spring-diaphragm operated
- 3/8"-1" NPT THD (can also be special ordered flanged 1/2' & up)
- Max Recommended Inlet pressure to 150 PSI (~10 Bar) based on diaphragm limitation
- Outlet pressures to 80 PSI (5.5 Bar) (multiple spring ranges)

## Features

- **Pressure-containing parts** made from solid bar stock materials — unlike castings which have wall thickness variations.
- **Body & Trim:** Alloy 20, Monel, Titanium, and Hastelloy
- **Elastomeric diaphragm** is reinforced and has a 300 psi (~20 bar) burst pressure rating permits maximum travel for high capacity. Available in Teflon (standard), Viton, and EPDM.
- **In-line porting** allows for simplified piping installation.

## Applications

Valve can be used for non-corrosive or mildly corrosive fluids, depending on the materials selected (consult factory). When liquids or gases contain debris or other solid matter which might cause internal clogging or improper operation of the valve, a strainer with a fine wire mesh should be installed before the inlet of the valve. In-line strainer fittings STF-05 or basket strainer models SBS-10 or SBV-05 can be purchased from Stra-Val to solve this problem.

This valve is similar to the model PRS-05, except that it can pass a much higher capacity because of the greater travel produced with the elastomeric diaphragm compared to a metal one. Do not use this valve on applications where the inlet pressure will fluctuate widely as it may require readjustment of the outlet pressure. However, where the condition does exist and the outlet pressure needs to be controlled closely, a **pressure reducing valve** with a balanced design is recommended.

Although the diaphragm has a 300 psi burst pressure limit, when the inlet pressure exceeds 80 psi (5.5 bar) a **relief valve** located on the outlet side of the valve is strongly recommended in case the seat is unable to hold back the full inlet pressure. This will assure that the diaphragm will not be subjected to excessive pressure which may cause it to fail prematurely.

## Principle of Operation

This is a direct-acting pressure-reducing valve with an adjustable spring operating against a flexible stainless steel diaphragm subjected to the reduced outlet pressure of the valve. With the spring completely uncompressed and adjusting screw backed out, the inlet pressure will close the main valve and keep it shut. This will shut off flow and reduce the outlet pressure to zero if the valve seat is sealing effectively.

Downstream sensing pressure is achieved with an internal sensing port, but can be supplied with an external means as an option.

---

## Notes

See pricing pages for material options

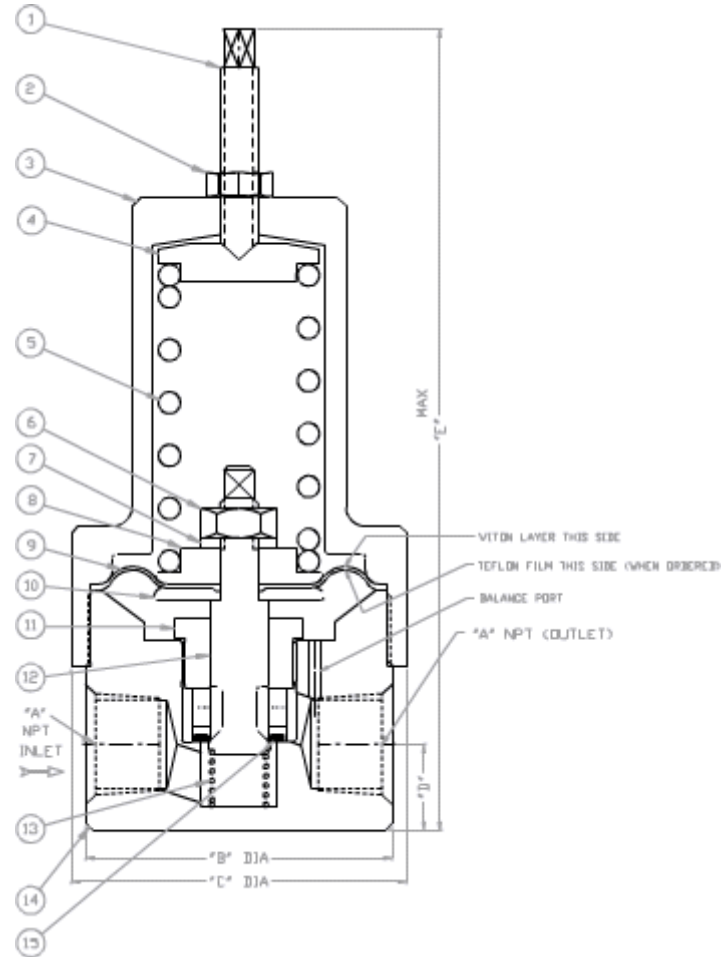

**PRS6-EX**  
For gases and liquids

**Material List and Specification**

#	Item	Materials
1.	Adjusting screw	St. Steel
2.	Lock nut	St. Steel
3.	Spring chamber	St. Steel
4.	Spring pusher	St. Steel
5.	Spring	CrSilStl
6.	Lock nut	St. Steel
7.	Lock washer	St. Steel
8.	Spring carrier	St. Steel
9.	Diaphragm	Teflon, Viton
10.	Diaphragm disc.	Hastelloy, Monel, Titanium, Alloy20
11.	Seat	Hastelloy, Monel, Titanium, Alloy20
12.	Main valve	Hastelloy, Monel, Titanium, Alloy20
13.	Spring	Stainless steel
14.	Body	Stainless steel
15.	Seat	Teflon or viton, or metal to metal

**3/8" PRS06-03T-EX**

**1/2" PRS06-05T-EX**

**Max inlet pressure 150 psi (10 barg) Rated press 300 psi(20 bar)**  
Multiple Spring Ranges from:2-80 psig (0.138-5.52 barg) Select spring from pricing page

---

## **3/4" PRS06-07T-EX**

**Max inlet pressure 150 psi (10 barg) Rated press 300 psi(20 bar)**  
Multiple Spring Ranges from:2-80 psig (0.138-5.52 barg) Select spring from pricing page

---

## **1" PRS06-10T-EX**

**Max inlet pressure 150 psi (10 barg) Rated press 300 psi(20 bar)**  
Multiple Spring Ranges from:2-80 psig (0.138-5.52 barg) Select spring from pricing page

---

The spring ranges listed above are not achievable with one spring, but are compressed to show overall product capability. Select a specific spring range in the pricing pages or specify a set pressure when ordering.