

# OPERATING INSTRUCTIONS

## MODEL BPS-09i NPT

### BACK PRESSURE CONTROL VALVE



If the poppet fails to open with the adjusting screw sufficiently backed out and the valve is under pressure, the poppet is probably frozen or corroded in place. If this condition exists, the valve must be **immediately removed from service** and replaced or repaired.

Another reason for replacing or repairing a valve is if there is excessive leakage from the valve seat. If this happens even with the spring compressed to the maximum (this should only be temporarily done for test purposes), this is an indication the poppet and or valve seat on the body is worn, damaged, corroded, or a particle lodged in the seat causing the valve to constantly leak. If leakage is observed through the spring adjusting screw, this indicates there is leakage

through the diaphragm, which requires replacement.

#### APPLICATIONS:

This valve is used for back pressure control applications such as maintaining constant pump discharge pressures, bypassing excessive pressures from various types of process equipment, and where ever a constant pressure must be maintained in a process or piping system. Valve can be used for -corrosive or mildly corrosive fluids, when the proper corrosion resistant materials are selected. When liquids or gases contain debris or other solid matter, which might cause internal clogging or improper operation of the valve, a strainer with a fine wire mesh should be installed before the inlet of the valve. In-line strainer fittings or basket strainers can be purchased from STRAVAL.

#### PRINCIPLE OF OPERATION

This is a direct acting valve with an adjustable spring operating against a diaphragm subjected to the inlet pressure of the valve. The pressure which acts on the underside of the diaphragm can come from the inlet port directly with an internally drilled sensing hole, or from an external source with a separate port, which is shown in the attached illustration. When the sensing is from an external source, there is an additional piston seal (12) to isolate the external sensing pressure from the inlet pressure. Increasing the spring compression will increase the system or line pressure to be maintained. Reducing the spring compression will reduce the system or line pressure to be maintained. An increase in system pressure beyond the set point will cause the main valve to open and relieve the excess pressure through the outlet port.

#### MAINTENANCE & REPAIR

The valve should be periodically checked for proper operation. This can be easily done by reducing the spring compression from its current pressure setting. Eventually the poppet should open and begin to discharge liquid or gas under pressure. **Make sure that the discharge is properly piped to a safe area in order avoid any personal injury.**

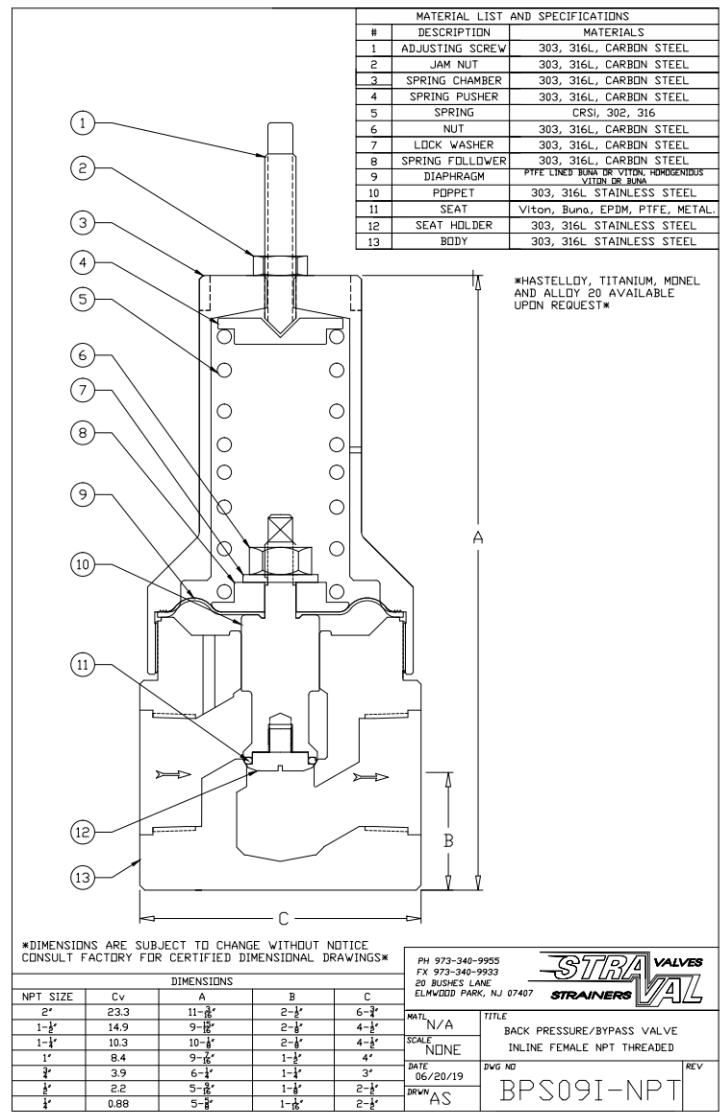



## OPERATING INSTRUCTIONS

### PROCEDURE FOR DISASSEMBLY

Make sure the valve is isolated and is not under pressure. Next remove the valve from the system. Back out the spring adjusting screw until there is no longer any spring compression. It may also be removed completely if desired. Unscrew the spring chamber using the flats provided on top of the spring chamber

Now the top of the poppet is exposed. While still assembled, test to see if the poppet is free to move by hand. There should only be a slight resistance to movement resulting from the O-ring friction between the piston and the body. The piston can now be pulled out through the top of the body. Examine the O-ring or seal to see if any deterioration has taken place and replace if necessary. Next examine the poppet seating surface where it contacts the body and the mating surface on the body. Usually if there is severe leakage, the condition of these seating surfaces will indicate a worn or deteriorated surface finish. If the seat leakage is only minor, a re-lapping procedure using a #600 lapping compound will usually solve the problem.

Examine the body bore where the piston or poppet is housed. If the surface is not smooth, the bore should be polished with a very fine abrasive paper or fine scotch brite. The same should be done with the piston or poppet outside diameter. These operations can be done in a small lathe. Use extreme caution when polishing the body so as not to get a finger caught in the discharge port if the body is rotating in a lathe while polishing may not even be possible to lap the valve in. If the bore requires re-machining, there is a risk that too much clearance will result in the seat not closing properly because of excessive side movement. Ordinarily the side clearance between the piston and body bore should only be about 0.001 to 0.0025 in depending on the size. Consult factory for proper clearances for your specific valve

If the valve is severely damaged and if it is not practical to re-machine because side clearances would be excessive, then a new valve should be purchased, or the valve shipped to STRAVAL for a repair evaluation, and possible repair or replacement. Don't forget to examine the adjusting spring to look for signs of corrosion or outright failure. Replace if necessary. Springs are usually always in stock at STRAVAL and can be shipped readily.

### REASSEMBLY & TEST

When all the valve parts are cleaned and inspected, the valve can be reassembled in reverse order.

Make sure a valve seal lubricant is used to lubricate the seal and is compatible with the elastomer used.

Make sure no dirt or foreign particles are embedded in the valve seat which might cause the valve seat to stay partially open and cause unwanted leakage.

When the spring and spring hardware is assembled and the spring chamber threaded on to the body tightly, the valve is ready for final installation and test.

Testing can be done in one of two ways. If the pressure is low, the adjusting screw can be loose and almost backed out all the way. Then while the valve is under the proper system pressure, the adjusting spring can be gradually turned in to compress the spring until the leakage stops.

### MODEL BPS-09 NPT

### BACK PRESSURE CONTROL VALVE

The ideal case is if the system pressure can be adjusted to the precise pressure condition that the valve must open at and then set the spring tension accordingly. If this is not possible or practical, then the above short cut procedure can be used. If the valve is expected to operate at the high end of the spring compression range, then it may be practical to adjust the spring pressure somewhere near the maximum and while the valve is under pressure and slowly begin to release the spring tension until the valve begins to open. At that moment the spring compression can be re-tightened to stop the discharge.